

## VERTIKA PURE

Proven solutions at **a reasonable price!**



Internal elements of unit  
**powder coated Ral colour 9005**  
(base shelf, support brackets)



**1**  
**Tiltable system of front glass**  
– easy cleaning system



**2**  
**Back sliding glass door** – facilitated access to stored products



**3**  
**Electronic controller with digital display of temperature**  
– accurate temperature control



**4**  
**Illuminated shelves (LED light)** – stored products look visually attractive



**5**  
**Glass shelves with height adjustment**  
– better exposure of the products

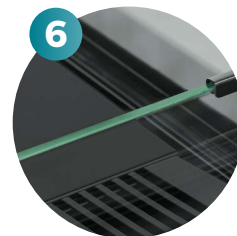

**6**  
**Optimal air circulation**



**NEW**



## VERTIKA PURE



### STANDARD EQUIPMENT

- Plug in (internal compressor)
- Electronic controller with digital display of temperature
- Dynamic cooling
- Automatic defrost
- Automatic evaporation of condensate
- Tilttable system of front glass
- Back sliding glass door
- Height adjustable glass shelves
- Illuminated shelves
- Internal elements of unit powder coated Ral colour 9005 (base shelf, support brackets)
- Device for individual build - over



### OPTIONAL EQUIPMENT

- Set of MDF external corners - colour patterns
- External body powder coated RAL colour

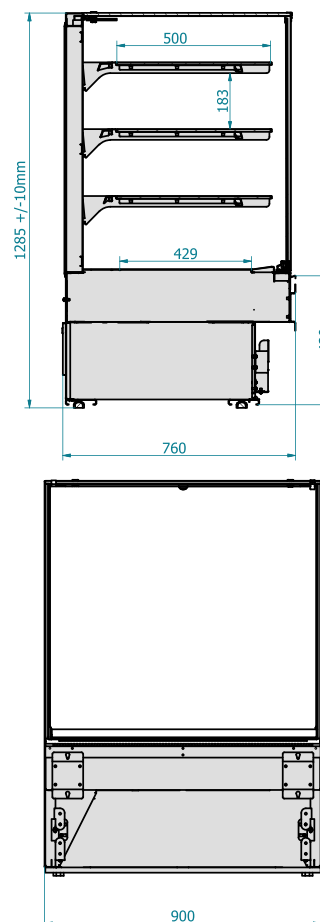

MODEL	TEMPERATURE RANGE [°C]	AMBIENT CONDITIONS [°C / RH]	EXPOSITION SURFACE [m²]	DIMENSIONS [mm - l x d x h]	NUMBER OF SHELVES	SHELF WIDTH [mm]	POWER SUPPLY [V / Hz]	NET WEIGHT [kg]	REFRIGERANT
Vertika Pure 600	+5...+15	+25 / 60%	0.81	600 x 760 x 1290	3+1	500	230 / 50	125	R290
Vertika Pure 900	+5...+15	+25 / 60%	1.71	900 x 760 x 1290	3+1	500	230 / 50	170	R290
Vertika Pure 1300	+5...+15	+25 / 60%	2.51	1300 x 760 x 1290	3+1	500	230 / 50	230	R290